

FACTORS FOR ADOPTION OF THE MILK RUN SYSTEM IN THE PARCEL TRANSPORTATION BUSINESS

Putthiwat Singhdong* and Suraporn Onputtha**

Department of International Business Administration , Rajamangala University of Technology Thanyaburi, Pathum Thani, Thailand

ABSTRACT

This study aimed to study factors for adopting the Milk Run system in the parcel transportation business in Thailand. Questionnaires were used as the research tool to collect data. The sample group in this study was 300 respondents who are employees of a parcel transportation service business. Descriptive statistics were analysed, including percentage, mean, standard deviation, inferential statistics, and structural equation modelling (SEM). The results reveal that perceived ease of use in the Milk Run system (PEU) had a positive impact on the service quality in the Milk Run system (QS) and the perceived benefit factor in the Milk Run system (PU). In addition, PU also positively impacted trust in the Milk Run system (TR), while PU, PEU, and QS had no impact on the intention to use the Milk Run system (ATT). However, only TR had an impact on ATT. This study also shows that ATT positively impacted the intention to use the Milk Run system (BI). The study highlights the significance of the implementation influence of the Milk Run system on parcel transportation and extends the current knowledge regarding the Milk Run system and its potential impact on the parcel transportation business in Thailand.

Keywords: Milk Run system, Adoption, Technology Acceptance Model, Parcel transportation business

บทคัดย่อ

การศึกษานี้มีวัตถุประสงค์เพื่อศึกษาปัจจัยที่ส่งผลต่อการนำระบบ Milk Run มาปรับใช้ในธุรกิจขนส่งพัสดุภัณฑ์ในประเทศไทย โดยใช้แบบสอบถามเป็นเครื่องมือในการวิจัยในการเก็บรวบรวมข้อมูล กลุ่มตัวอย่างในการศึกษานี้คือผู้ตอบแบบสอบถามจำนวน 300 คน ซึ่งเป็นพนักงานของธุรกิจบริการขนส่งพัสดุภัณฑ์ ทำการวิเคราะห์ข้อมูลด้วยสถิติเชิงพรรณนา ได้แก่ ร้อยละ ค่าเฉลี่ย ส่วนเบี่ยงเบนมาตรฐาน สถิติอนุมาน และการสร้างแบบจำลองสมการ โครงสร้าง (SEM) ผลการวิจัยพบว่า การรับรู้ถึงความง่ายในการใช้งานในระบบ Milk Run (PEU) ส่งผลดีต่อคุณภาพการบริการในระบบ Milk Run (QS) และการรับรู้ถึงประโยชน์ปัจจัยในระบบ Milk Run (PU) นอกจากนี้ ในระบบ Milk Run (PU) ยังส่งผลใน

Received September 29, 2021; Revised November 20, 2021; Accepted November 30, 2021

*Dr. Putthiwat Singhdong is a lecturer in Faculty of Business Administration at Rajamangala University of Technology Thanyaburi.
Email: putthiwat_s@rmutt.ac.th

**Dr. Suraporn Onputtha is a lecturer in Faculty of Business Administration at Rajamangala University of Technology Thanyaburi.
Email: suraporn_o@rmutt.ac.th

ในเชิงบวกต่อความไว้วางใจในระบบ Milk Run (TR) ในขณะที่ การรับรู้ถึงประโยชน์ (PU) การรับรู้ถึงความง่าย (PEU) และ คุณภาพการบริการ (QS) ไม่มีผลกระทบต่อความตั้งใจที่จะใช้ระบบ Milk Run (ATT) อย่างไรก็ตาม มีเพียง ความไว้วางใจ (TR) เท่านั้นที่มีผลกระทบต่อความตั้งใจที่จะใช้ระบบ (ATT) การศึกษานี้ยังแสดงให้เห็นว่าความตั้งใจที่จะใช้ระบบ (ATT) ส่งผลในเชิงบวกต่อความตั้งใจที่จะใช้ระบบ Milk Run (BI) ผลการศึกษานี้ชี้ให้เห็นถึงความสำคัญของอิทธิพลการดำเนินงานของระบบ Milk Run ต่อการขนส่งพัสดุ และขยายความรู้ในปัจจุบันเกี่ยวกับระบบ Milk Run และผลกระทบที่อาจเกิดขึ้นต่อธุรกิจขนส่งพัสดุในประเทศไทย

คำสำคัญ: ระบบมิลค์รัน, การยอมรับ, แบบจำลองการยอมรับเทคโนโลยี, ธุรกิจขนส่งพัสดุ

INTRODUCTION

Globally, logistics business has entered a boom period and can be accounted as the important mechanism to drive country economic and respond the needs of consumers; accordingly, the transportation industry must constantly develop in order to maintain its competitiveness and effectiveness. Literally, Blanco and Sheffi (2017) discuss how logistics plays a role in assuring the availability of raw materials, inventories, semi-finished products, and final items. Products in the manufacturing cycle are designed to please consumers at the lowest possible cost, which means that logistics also contributes to increased production capacity and commercial growth (Nguyen & Tran, 2019). In addition, Onputtha, Sriboonlue and Sriboonlue (2021) advocated that logistics business is so interesting and needs rooms for more development and improvement in order to obtain the organizational performance.

One of the most interesting and important logistics businesses in the country's economy is the parcel logistic business, which is growing with the trend of e-commerce shopping online that has become one of the lifestyles of people in the present era and with the Covid-19 crisis that changes that consumer behavior which finally had a positive impact on the logistics business (Lim & Shiode, 2011; Liu et al., 2020). Additionally, Perboli and Rosano (2019) advocated that the importance of freight transportation and parcel delivery in urban areas has grown in recent years, assisting cities' economic and social growth. However, the parcel delivery business faces quite intense competition from its competitors, such as the competition for fast service, low-cost service, effective environmental management, or high-quality service efficiency (Vakulenko, Hellström, & Hjort, 2018; Perboli & Rosano, 2019; Gläser, Jahnke & Strassheim, 2021). Because of this, the parcel logistics industry must always explore for new ways to conduct business in order to become more profitable and effective and to obtain customers' satisfaction (Vakulenko, Hellström & Hjort, 2018).

One of the most fascinating tactics for this logistics company is the Milk Run transportation system that comes with the advancement of information technology. The Milk Run transportation system has significant effects on various businesses including the parcel logistics industry. Milk-Run logistics is a general term for a technique of logistics procurement that relies on routing to combine the buyer's commodities (Sadjadi, Jafari & Amini, 2009). Using this strategy, the user (i.e. vehicle assembly company) assigns one truck at a certain time to visit numerous suppliers (i.e. components

supplier) following a planned route to collect parts or products, and bring them to the factory (Brar, & Saini, 2011). The milk run system has its advantages for the companies since it is all about to support the supply chain and it can result in cost savings associated with transportation, travel routes, and fuel usage, all of which contribute to an organization's overall success, both financial and non-financial (Brar & Saini, 2011; Putra, Ridwan & Astuti, 2019; Simić et al., 2021).

Nevertheless, the most significant issue that many parcel logistics industries are encountering with is that there have been obstacles interrupting the adoption of the milk run transportation system (You & Jiao, 2014; Qu et al., 2015; Mácsay & Bányaí, 2017). In order to achieve successful Milk Run system adoption, the concept of technology acceptance model (TAM) has been proposed in this study since it can have an impact of logistics service systems. It is believed that attitudes of technology acceptance can enable the business to enter into the technological era as well as covid 19 crisis (Hofmann & Rüsç, 2017; John & Thakur, 2021). The result of this study can provide guidelines to implementation of the Milk Run system on parcel transportation and extends the current knowledge regarding the Milk Run system.

The objectives of the study were to study factors that can affect the adoption of the Milk Run system in the parcel transportation business in Thailand.

LITERATURE REVIEW

Technology Acceptance Model (TAM)

The technology acceptance model (TAM) is based on the theory of reasoned action (TRA) and the principle of cause and effect (Marangunić & Granić, 2015). TAM explains that human behaviour and the factors that influence the use of computer technology are based on users' attitudes. The difference between the technology acceptance model (TAM) and the theory of reasoned action (TRA) is that TRA focuses on intention and behaviour and measures consumers' attitudes towards technology adoption and actual use factors. TAM has been used to study the adoption of technology in logistics businesses. For example, Bienstock and Royne (2010) aimed to study by using the technology acceptance model (TAM) from the information technology (IT) literature to evaluate the correlations between technology use/acceptance and customer satisfaction with logistics services, and both perceptions of logistics service quality (LSQ) and satisfaction levels are shown to be highly associated with future purchase intentions.

Furthermore, LSQ perceptions operate as a mediator between the two TAM components and customer satisfaction. Meanwhile, Utami et al. (2018) sought to ascertain the effect of perceived usefulness and user satisfaction on the business strategy of the Industrial and Maritime Trade Unit, and the study's findings indicate that the variable utilities have a significant effect on the satisfaction of E-Logis users, amounting to 25.6 percent. In addition, Hwang & Song (2019) used the technology acceptance model to examine the factors affecting the acceptance of logistics robots in fulfillment centers and discovered that both ease and usefulness of purchasing have a significant effect, with ease having the greatest effect; the more experience involved, the more innovative, the more positive.

Milk Run System Concept

The Milk Run transport system imitates the milk transport system in the United States: dairy farms arrange a pick-up truck and deliver Milk daily (Meyer, 2017). After the Milk has been consumed, empty milk bottles are put in front of the following day; the milk truck will bring new milk bottles to customers and pick up the empty bottles back to the milk farm (Droste & Deuse, 2012). This milk distribution concept has been developed and become the Milk Run transport model, which provides greater flexibility in raw material management. In other words, a car can also be used to pick up raw materials and products from various suppliers and deliver to the company (You & Jiao, 2014). In large industry, Staab et al. (2016) mentioned that milk-run trains often share resources, such as loading spaces and technology, and operate on the same tracks, resulting in route dependencies and probable traffic jams and obstructions that dramatically influence cycle durations and may result in system instabilities. The practical systems used among delivery and transportation agencies are as follows:

1. Milk Run system: the manufacturer arranges trucks to pick up raw materials and goods at the place of raw material suppliers. The first manufacturer that adopted this system was Toyota Company Limited.
2. Non-Milk Run System: a system that suppliers deliver raw materials and goods to the manufacturer. Most manufacturers use this system.

From related previous studies, You & Jiao (2014) advocated that milk-run schema may benefit the express sector by reducing logistics costs via the optimization of distribution schemas with the goal of providing timely and efficient express service, resolving the shortest distance, and achieving the lowest cost minimum objective. Meanwhile, Purba, Fitra and Nindiani (2019) conducted a study on Milk Run with the objective of analyzing the practice of milk-run operation in one of the largest Japanese automotive companies in Indonesia. The study discovered that while the company still needs to improve milk-run operation, the benefit of milk-run operation is cost reduction and also supports green logistics by reducing the number of trucks used. Furthermore, dos Santos et al. (2021) added that the concepts of Kanban and Milk Run, through a direct observation of a motorcycle factory and an electronics assembly factory, can better organization for the logistics teams in terms of developing a fast, feasible and low-cost solution.

Hypotheses of the research

The hypotheses are herewith proposed to indigenize the linkage for adopting the Milk Run system in parcel transportation business in Thailand.

- Hypothesis 1 (H1): PEU has a positive impact on QS.
- Hypothesis 2 (H2): PEU has a positive impact on PU.
- Hypothesis 3 (H3): QS has a positive impact on TR.
- Hypothesis 4 (H4): PU has a positive impact on ATT.
- Hypothesis 5 (H5): PEU has a positive impact on ATT.
- Hypothesis 6 (H6): QS has a positive impact on ATT.
- Hypothesis 7 (H7): TR has a positive impact on ATT.
- Hypothesis 8 (H8): ATT has a positive impact on BI.

Remarks:

PEU = Perceived ease of use of Milk Run system, QS = Service quality in using Milk Run system,

30

PU = Perceived benefit in Milk Run system, TR = Trust in Milk Run system, ATT = Attitudes toward Milk Run system, BI = Intention to use Milk Run system

Research Framework

Figure 1: Research Framework

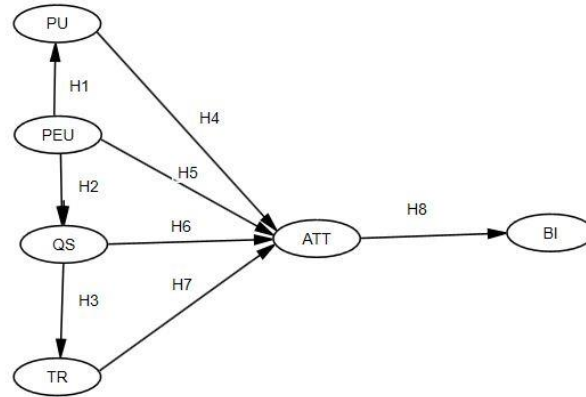

Table 1: Milk Run System based on Technology Acceptance Model Factors

Construct	Number	Items	Factors Criteria
Perceived benefit factor	1	PU1	The Milk Run transport system reduces confusion in the delivery of goods.
	2	PU2	The Milk Run transport system significantly reduces working time.
	3	PU3	The Milk Run transport system reduces the cost of transportation and storage.
Perceived ease of use	4	PEU1	Transportation becomes more accessible with the adoption of the Milk Run transport system.
	5	PEU2	The Milk Run operational system is uncomplicated.
Attitude toward Milk Run system	6	ATT1	The Milk Run transport system is satisfactory.
	7	ATT2	The Milk Run transport system is essential for transportation.
	8	ATT3	Users are ready and willing to use the Milk Run transport system.
Service quality in Milk Run system	9	QS1	The Milk Run transport system provides the shortest distance to reach the destination.
	10	QS2	The Milk Run transport system can maximize the potential of resource allocation.
	11	QS3	The Milk Run transport system can meet the satisfaction of cost management.
Trust in Milk Run system	12	TR1	The Milk Run transport system can deliver products to customers within the specified time.
	13	TR2	The Milk Run transport system can build trust for the company.
	14	TR3	Participants can find details of the transport and access to the services provided by the Milk Run transport system.
Intention to use Milk Run system	15	BI1	Users are aware of the importance of the Milk Run transport system.
	16	BI2	The Milk Run transport system is more efficient than expected.
	17	BI3	The Milk Run transport system can be applied at work.

Source: adapted from Marangunić and Granić (2015).

METHODOLOGY

Quantitative research in the form of survey research and closed-end questionnaire was used in this study to find factors for adopting the Milk Run transport system in the parcel transportation business (PTB). The following points are to describe population and sampling, data collection, and data analysis.

Population and Sampling

The targeted population was employees of a parcel transportation business (PTB) in Thailand. To determine the sample size, the method of Taro Yamane (1973) and purposive and convenience random sampling were used. The total sample was 300.

Data Collection

The data collection was conducted through both primary and secondary sources. For primary sources, the self-completed questionnaire was distributed to 300 employees of the parcel transportation business (PTB) in Thailand as the sample of this study. The steps of designing questionnaire for data collection were as follows:

1. The researchers reviewed the relevant theories and literatures in order to create the questionnaire and then send the questionnaire to three experts on the related fields to apply in this research in order that they would give the comments for further development. This process is called index of objective congruence (IOC). After the questionnaire was given the feedbacks, the edition and revision in line with provided comments were constructed.
2. After edition and revision of the questionnaire, the researchers conducted the pilot test with 30 sets of questionnaires sent to similar population groups who are not the study samples. This stage involves reliability test derived Cronbach's alpha with higher than 0.70. However, the study obtained Cronbach's alpha of 0.86 which is higher than value requirement, meaning that items in the questionnaires can be used for further analysis.
3. After the reliability was performed, the researchers distributed 300 sets of the questionnaire to the target samples. The respondents were asked to return the filled in the questionnaire.

In addition, the data used in this study also was obtained from the secondary data sources: journals, documents, magazines, the Internet, and other sources. These data from these sources would be used to support the study result as the evidence.

Data Analysis

Descriptive statistics, including percentage, mean, standard deviation, and inferential statistics, were used to evaluate the respondents' demographic information as well as attitudes of the parcel transportation business employees towards technology acceptance model on adopting Milk Run transport system into parcel transportation business. Kurtosis and skewness were also used to measure the symmetry of the distribution and heaviness of the distribution tails which the values and the broader range should be between +3 to -3 (Hair, 2006). In addition, the structural model equation (SEM) with good-fit indices as well as construct validity and convergent validity was utilized to test the relationships between variables in stated hypothesis 1-8. If there is a need to modify the model, modification indices (MI) are required (Oort, 1998; Sanders et al., 2015).

RESULTS

In Table 2, the test results show that all values for the items are within the rigorous range of values and the broader range of +3 to -3 kurtosis and skewness range (Hair, 2006). From the study, these values failed into acceptable level, meaning that there are no multivariate non-normal issues within the dataset.

Table 2: Descriptive Statistics

Variable	N	min	max	skew	kurtosis
TR3	300	2	5	-0.489	-0.466
PEU1	300	2	5	-0.636	0.131
PEU2	300	2	5	-0.56	0.016
PU1	300	2	5	-0.666	-0.256
PU2	300	2	5	-0.519	-0.314
PU3	300	2	5	-0.498	-0.402
BI3	300	2	5	-0.466	-0.136
BI2	300	2	5	-0.421	-0.492
BI1	300	2	5	-0.445	-0.228
ATT1	300	3	5	-0.368	-0.776
ATT2	300	2	5	-0.488	-0.211
ATT3	300	2	5	-0.5	-0.442
TR1	300	1	5	-0.841	1.005
TR2	300	2	5	-0.522	-0.28
QS1	300	1	5	-0.953	0.803
QS2	300	1	5	-0.887	0.959
QS3	300	2	5	-0.481	-0.578

Table 3: Reliability and Validity Results

Construct	No.	Items	CR	AVE	CB
Perceived benefit factors	1	PU1	0.80	0.58	0.806
	2	PU2			
	3	PU3			
Perceived ease of use	4	PEU1	0.72	0.56	0.806
	5	PEU2			
Attitude toward Milk Run system	6	ATT1	0.81	0.59	0.803
	7	ATT2			
	8	ATT3			
Service quality in Milk Run system	9	QS1	0.75	0.50	0.789
	10	QS2			
	11	QS3			
Trust in Milk Run system	12	TR1	0.75	0.50	0.751
	13	TR2			
	14	TR3			
Intention to use Milk Run system	15	BI1	0.75	0.50	0.751
	16	BI2			
	17	BI3			

Cronbach's alpha was used to assess the reliability. The results show the values as follows: the perceived benefit factor was 0.806, the perceived ease of us was 0.806, the attitude towards the

Milk Run system was 0.803, the service quality in the Milk Run system values was 0.789, the trust in the Milk Run system was 0.751, and the intention to use the Milk Run system was 0.745. All of the values were greater than 0.70. The convergent and discriminant validities of the constructs were also determined. Three indices were used to assess concurrent validity: mean extracted variance (AVE) values should be greater than 0.5, and the composite reliability (CR) values should exceed 0.07. The degree of factors that help in distinguishing one construct from another is called discriminant validity. Overall, the test results showed a satisfactory construct validity level in the convergent and divergent validity contexts, implying that the research constructs were a suitable fit for a structural model assessment. The initial model was formed and used to test the hypotheses. The model fit indices were employed to ensure whether the model could be empirically formed. If there is a need to modify the model, modification indices (MI) are required (Oort, 1998; Sanders et al., 2015). The study presents the results related to model-fit indices, standardized estimates, errors, t-values (critical ratio, CR), p-values, total effects, direct effects, and indirect effects.

Figure 2: Final Model

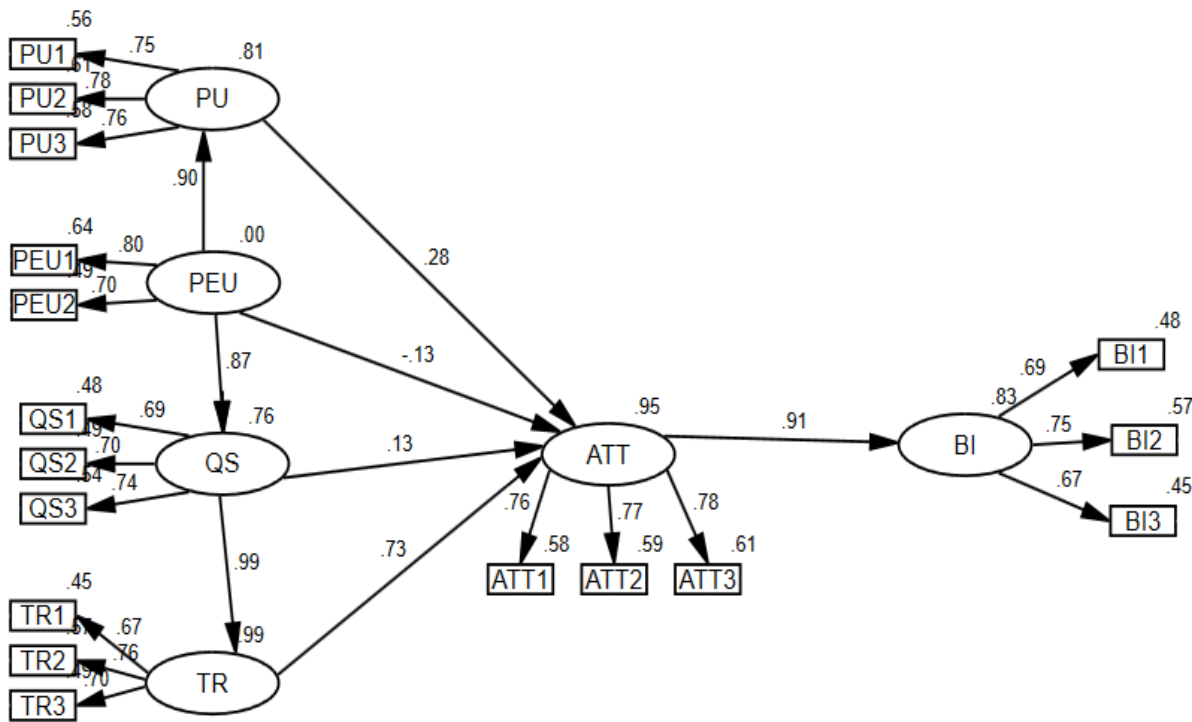

Table 4: GOF Measurement Model

Chi-square		Absolute Fit Indices		Incremental Fit Indices	
p-value	0.00	RMSEA	0.70	CFI	0.942
CMIN/df	2.345	RMR	0.022	TLI	0.929
		GFI	0.905	NFI	0.906

Table 4 presents the Goodness-of-Fit measurement model that correlates relevant items. Consequently, the model gained better model-fit indices: p-value of 0.00, CMIN/df of 2.345, GFI of 0.905, RMSEA of 0.70, RMR of 0.022, CFI of 0.942, TLI of 0.929, and NFI of 0.906. The results indicate that the model correctly fits the measurement, and the fit indices have acceptable values. Thus, this data set can be used for further analysis.

Table 5: Hypothesis Testing

Hypothesis	Path	Loading	S.E.	T -Value	P value	Results
1	QS <--- PEU	0.871	0.087	10.373	***	Support
2	PU <--- PEU	0.900	0.090	10.729	***	Support
3	TR <--- QS	0.993	0.085	11.037	***	Support
4	ATT <--- PU	.282	0.148	1.904	0.057	Not Support
5	ATT <--- PEU	-.128	0.237	-0.581	0.561	Not Support
6	ATT <--- QS	0.127	2.741	0.048	0.962	Not Support
7	ATT <--- TR	0.732	2.87	0.28	***	Support
8	BI <--- ATT	0.914	0.063	11.367	***	Support

The results of the regression analysis indicate that perceived PEU creates a positive impact on QS ($\beta = 0.871$; S.E. = 0.087; T vale = 10.373, and $p < 0.001$). Thus, H1 is accepted. PEU has a positive impact on PU ($\beta = 0.900$; S.E = 0.09, and $p < 0.001$). Thus, H2 is accepted. QS has a positive impact on TR ($\beta = 0.993$; S.E. = 0.085, and $p < 0.001$) Thus, H3 is accepted. For Hypotheses 4, 5, and 6, the SEM results also reveal that PU, PEU, and QS have a significant negative influence on ATT ($\beta = 0.282, -0.128, \text{ and } 0.127$ respectively), while S.E. = 0.944, 0.830, and 0.945, $p > 0.001$). Thus, H4, H5 and H6 are rejected. However, TR has a positive influence on ATT ($\beta = 0.732$; S.E. = 2.87; T vale = 0.28, and $p < 0.001$). Thus, H7 is rejected. Lastly, ATT has a positive impact on BI ($\beta = 0.914$; S.E. = 0.063, and $p < 0.001$). Thus, H8 is accepted.

SUMMARY AND CONCLUSIONS

This study explored and confirmed the influence of the Milk Run system adoption, based technology acceptance model (TAM), in the parcel transportation business (PTB) in Thailand. The factors of Milk Run system, based on TAM consisted of perceived ease of use (PEU), service quality (SQ), perceived benefit (PU), trust (TR), attitudes (ATT), and intention (BI) to use Milk Run system. After the conduction of structural equation modeling, the results indicated that PEU had a positive impact on QS, PEU had a positive impact on PU, QS had a positive impact on TR, and ATT had a positive impact on BI. However, PU, PEU and QS ATT did not have a positive impact on BI. This is because that the employees who will be willing to adjust themselves into use of the Milk Run system needs to know that the transportation becomes more accessible with the adoption of the Milk Run transport system and it is uncomplicated. If the employees feel fear with the technology, they will scare of using it. After they understand about the perceived ease of use, they will get to know that the Milk Run transport system can lead to reduces confusion in the delivery of goods; working time; and the cost of transportation and to provide the shortest distance to reach the destination; maximize the potential of resource allocation; and to meet the satisfaction of cost management. As a result, it can link to create the trust on Milk Run transport system and intend to continuously use the system. Consequently, the result is corresponding with the study

done by Utami et al. (2018) who ascertained the effect of perceived usefulness and user satisfaction on the business strategy of E-Logis users of the Industrial and Maritime Trade Unit. In addition, Hwang, & Song (2019) also affirmed from their study on the technology acceptance model to examine the factors affecting the acceptance of logistics robots in fulfillment centers and discovered that both ease and usefulness of purchasing have a significant effect on using logistics robots in fulfillment centers.

LIMITATIONS AND FUTURE RESEARCH DIRECTIONS

Regarding the results of the study, the Milk Run transport system can be considered as the important factor for the company which it is similar to study done by Staab et al. (2016) who advocated that milk-run trains often share resources, such as loading spaces and technology, and operate on the same tracks, resulting in route dependencies and probable traffic jams and obstructions that dramatically influence cycle durations and may result in system instabilities. Similarly, Purba, Fitra and Nindiani (2019) discovered that milk-run operation can provide the benefit in terms of cost reduction and also supports green logistics by reducing the number of trucks used for the company. Furthermore, dos Santos et al. (2021) added that the concepts of Kanban and Milk Run, through a direct observation of a motorcycle factory and an electronics assembly factory, can better organization for the logistics teams in terms of developing a fast, feasible and low-cost solution.

Therefore, the Milk Runs should become a cornerstone of PTB practices. It is recommended that firms should impose transport policies and apply the system to the process. The Milk Run system can effectively enhance firms to remain balanced while implementing the system and gaining trust. In addition, this study provides practical knowledge regarding factors that require attention to gain benefits and avoid risk by classifying serious risk issues in the parcel transportation process. By applying the Milk Run system, parcel transportation businesses can deliver products to customers within the specified time. Mainly, perceived ease of use is essential for service quality. The perceived benefit in Milk runs the system, perceived ease of use and service quality negatively impacts the attitude towards the Milk Run system, related to the intention to use the system. For future studies, the efficiency of the Milk Run system and other competitive systems in a wide range of logistics platforms should be comparatively studied. Furthermore, the other factors such as organizational strategies, organizational culture as well as internal-external business environment that can potentially link to better perceived ease of use (PEU), service quality (SQ), perceived benefit (PU) and trust (TR) should be considered since these variables are statistically significant for attitudes and intention to implement the technology. Lastly, the study in this time focuses more on qualitative approach, which the next research can apply qualitative approach to obtain insight of potential implication of Milk Run system or other technology related system to respond the industry 4.0 as well as digitalization era.

REFERENCES

Bienstock, C. C., & Royne, M. B. (2010). Technology acceptance and satisfaction with logistics services. *The International Journal of Logistics Management*, 21(2), 271-292.

- Blanco, E. E., & Sheffi, Y. (2017). *Green logistics*. In Sustainable Supply Chains (pp. 147-187). Springer, Cham.
- Brar, G. S., & Saini, G. (2011, July). Milk run logistics: literature review and directions. In Proceedings of the world congress on engineering (Vol. 1, pp. 6-8). WCE.
- Dos Santos, V. H. O., de Oliveira, M. A., & de Mattos Veroneze, G. (2021). Supply Chain System Model of Components for Assembly Lines Based on Kanban and Milk Run Methodologies. *European Journal of Engineering and Technology Research*, 6(6), 139-144.
- Droste, M., & Deuse, J. (2012). A planning approach for in-plant Milk Run processes to optimise material provision in assembly systems. In Enabling Manufacturing Competitiveness and Economic Sustainability (pp. 604-610). Springer, Berlin, Heidelberg.
- Fan, X., Thompson, B., & Wang, L. (1999). Effects of sample size, estimation methods, and model specification on structural equation modeling fit indexes. *Structural Equation Modeling: A Multidisciplinary Journal*, 6(1), 56-83.
- Fritz, M. S., & MacKinnon, D. P. (2007). Required sample size to detect the mediated effect. *Psychological Science*, 18(3), 233-239.
- Gläser, S., Jahnke, H., & Strassheim, N. (2021). Opportunities and challenges of crowd logistics on the last mile for courier, express and parcel service providers—a literature review. *International Journal of Logistics Research and Applications*, 1-29.
- Hair, J. F., Black, W. C., Babin, B. J., Anderson, R. E., & Tatham, R. (2006). *Multivariate data analysis*. Uppersaddle River.
- Hwang, H. C., & Song, S. H. (2019). A Study on the Factors Affecting the Acceptance of Logistics Robot in the Fulfillment Center Using the Technology Acceptance Model. *Journal of the Korea Academia-Industrial Cooperation Society*, 20(12), 287-297.
- Iacobucci, D. (2010). Structural equations modeling: Fit indices, sample size, and advanced topics. *Journal of Consumer Psychology*, 20(1), 90-98.
- Janjevic, M., & Winkenbach, M. (2020). Characterising urban last-mile distribution strategies in mature and emerging e-commerce markets. *Transportation Research Part A: Policy and Practice*, 133, 164-196.
- John, J., & Thakur, R. (2021). Long term effects of service adaptations made under pandemic conditions: the new “post COVID-19” normal. *European Journal of Marketing*, 55(6), 1679-1700.
- Lan, S., Yang, C., & Huang, G. Q. (2017). Data analysis for metropolitan economic and logistics development. *Advanced Engineering Informatics*, 32, 66-76.
- Lim, H., & Shiode, N. (2011). Parcel distribution networks for online shopping business. In Transportation and economic development challenges. Edward Elgar Publishing.
- Liu, W., Liang, Y., Bao, X., Qin, J., & Lim, M. K. (2020). China's logistics development trends in the post COVID-19 era. *International Journal of Logistics Research and Applications*, 1-12.
- Mácsay, V., & Bányai, T. (2017). Toyota production system in milkrun based in-plant supply. *Journal of Production Engineering*, 20(1), 141-146.
- Marangunić, N., & Granić, A. (2015). Technology acceptance model: a literature review from 1986 to 2013. *Universal Access in the Information Society*, 14(1), 81-95.
- Meyer, A. (2017). Milk Run design: Definitions, concepts and solution approaches (Vol. 88). KIT Scientific Publishing.
- Muthén, B. O. (2002). Beyond SEM: General latent variable modeling. *Behaviormetrika*, 29(1), 81-117.

- Nguyen, N. T., & Tran, T. T. (2019). Raising opportunities in strategic alliance by evaluating efficiency of logistics companies in Vietnam: a case of Cat Lai Port. *Neural Computing and Applications*, 31(11), 7963-7974.
- Oort, F. J. (1998). Simulation study of item bias detection with restricted factor analysis. *Structural Equation Modeling: A Multidisciplinary Journal*, 5(2), 107-124.
- Onputtha, S., Sriboonlue, U., & Sriboonlue, O. (2021). The Role of Knowledge Transfer among Creative Behavior, Green Service Behavior and Environmental Performance In Logistics Service Industry. *Journal of Management Information and Decision Sciences*, 24(4), 1-12
- Perboli, G., & Rosano, M. (2019). Parcel delivery in urban areas: Opportunities and threats for the mix of traditional and green business models. *Transportation Research Part C: Emerging Technologies*, 99, 19-36.
- Purba, H. H., Fitra, A., & Nindiani, A. (2019). Control and integration of milk-run operation in Japanese automotive company in Indonesia. *Management and Production Engineering Review*, 10(1), 79-88.
- Putra, F. M. A. M., Ridwan, A. Y., & Astuti, M. D. (2019, August). Material Handling Performance Measurement and Metrics for Internal Milk-Run Area using Overall Transportation Effectiveness. Case Study: Automotive Industry. In IOP Conference Series: Materials Science and Engineering (Vol. 598, No. 1, p. 012080). IOP Publishing.
- Qu, T., Chen, Y. D., Wang, Z. Z., Nie, D. X., Luo, H., & Huang, G. Q. (2015, April). *Internet-of-Things-based just-in-time milk-run logistics routing system*. In 2015 IEEE 12th International Conference on Networking, Sensing and Control (pp. 258-263). IEEE.
- Sadjadi, S. J., Jafari, M., & Amini, T. (2009). A new mathematical modeling and a genetic algorithm search for milk run problem (an auto industry supply chain case study). *The International Journal of Advanced Manufacturing Technology*, 44(1), 194-200.
- Sanders, S. J., He, X., Willsey, A. J., Ercan-Sencicek, A. G., Samocha, K. E., Cicek, A. E., ... & Autism Sequencing Consortium. (2015). Insights into autism spectrum disorder genomic architecture and biology from 71 risk loci. *Neuron*, 87(6), 1215-1233.
- Simić, D., Svirčević, V., Corchado, E., Calvo-Rolle, J. L., Simić, S. D., & Simić, S. (2021). Modelling material flow using the Milk run and Kanban systems in the automotive industry. *Expert Systems*, 38(1), e12546.
- Sinhhdong, P., Suthiwartnarueout, K., & Pornchaiwiseskul, P. (2021). Factors Influencing Digital Transformation of Logistics Service Providers: A Case Study in Thailand. *The Journal of Asian Finance, Economics and Business*, 8(5), 241-251.
- Staab, T., Klenk, E., Galka, S., & Günthner, W. A. (2016). Efficiency in in-plant milk-run systems—The influence of routing strategies on system utilization and process stability. *Journal of Simulation*, 10(2), 137-143.
- Utami, L. A., Kholil, I., Mazia, L., & Aulianita, R. (2018, August). Analysis of Electronic Logistics (E-Logis) System Acceptance Using Technology Acceptance Model (TAM). In 2018 6th International Conference on Cyber and IT Service Management (CITSM) (pp. 1-6). IEEE.
- Vakulenko, Y., Hellström, D., & Hjort, K. (2018). What's in the parcel locker? Exploring customer value in e-commerce last mile delivery. *Journal of Business Research*, 88, 421-427.
- Yamane, T. (1973). *Statistics: An introduction analysis*. Harper & Row.
- You, Z., & Jiao, Y. (2014). Development and application of milk-run distribution systems in the express industry based on saving algorithm. *Mathematical Problems in Engineering*, 2014, 1-6.